

## GORTITE® POWERED ROLL-UP DOOR

Automate Access to Vehicle Compartments & Cargo Areas

Dynatect draws on decades of experience in doors and automation to offer a powered roll-up door solution, incorporating features such as:

- Operator safety
- Door reliability
- Minimal doorway obstructions
- Simplified wiring
- Strong security, power-loss bypass options
- Scalable controller from hardwire inputs to automotive protocols



*Ideal for rear doors or side doors on step vans*

### Safest Mechanical & Electronic Design

- Three simultaneous modes of motion control...
  - Overcurrent sensing for obstruction detection and auto-reverse
  - Hardwire door sensors for open and close
  - Door travel time-out limits
- Anti-pinch cover shrouds the drive mechanism
- Positively driven open and close which keep doors from drifting closed when partially opened or on a hill
- Heat management to support (5) open/close cycles every minute

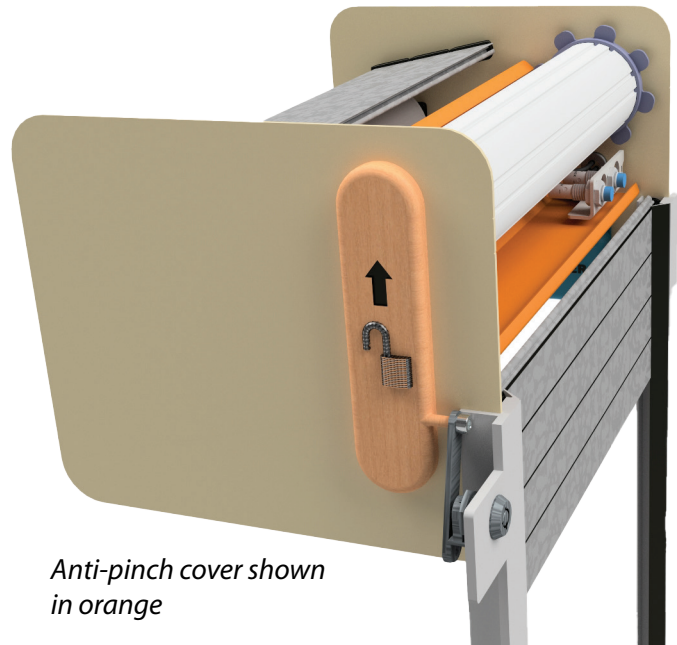

*Anti-pinch cover shown in orange*

**SAFETY - SECURITY - SPEED - COMPATIBILITY**

# GORTITE® POWERED ROLL-UP DOOR

## Self-Contained Powered Door Solution

- Motor/gearbox fits into existing idler tube envelope – no increased footprint
- Controller mounted to header assembly
- Integrated end-of-travel sensors without wiring down the leg of the door
- Powered auto-lock located in header, without wiring down the leg of the door, eliminating the trip hazard of bottom mounted locks

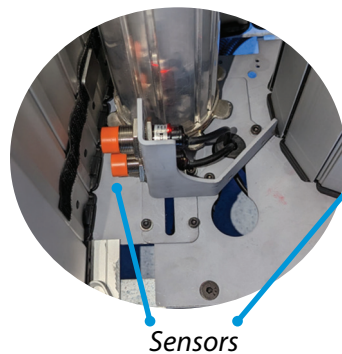

Door slats are positively driven open and closed via cogs on both sides

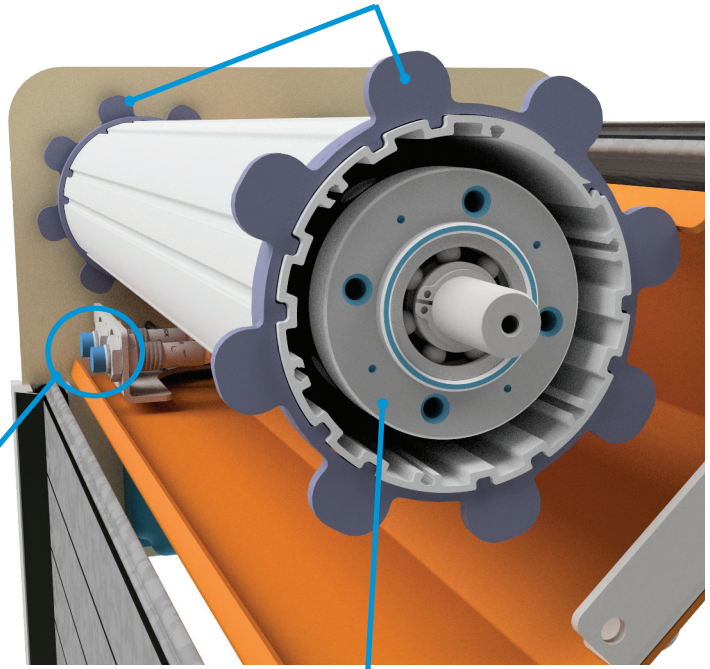

## Security and Power-Loss Protection

- Low battery cutoff prevents high-current draw or erratic operation
- Manual release can be activated from inside the compartment if power is lost
- Optional manual release from outside the compartment via keyed interface

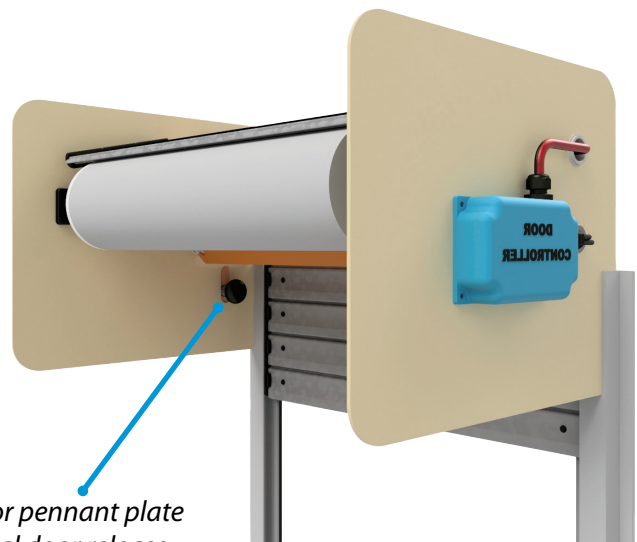
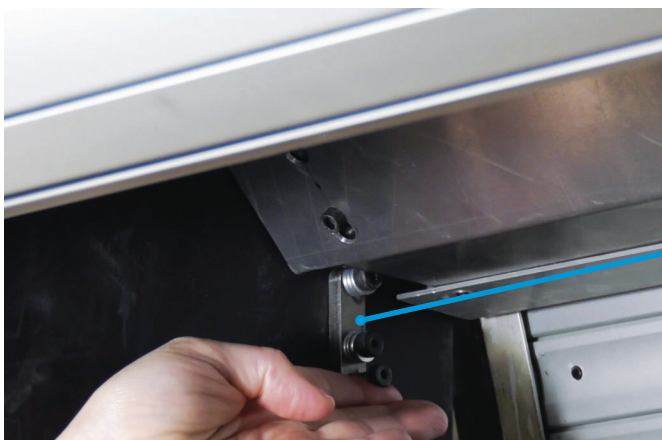

## Most Versatile Controller

- Fast travel: ~1 foot/second
- Designed for operating environments  
-40° F to +140° F
- Included communications:
  - Hardwire I/O (door-open/door-close)
  - FOB RF remote control
- Optional communications:
  - Wireless outdoor keypad
  - Bluetooth with companion app
  - Hardwire network interface to vehicle's  
body control module (BCM) via  
automotive CAN SAE J1939 500kbs

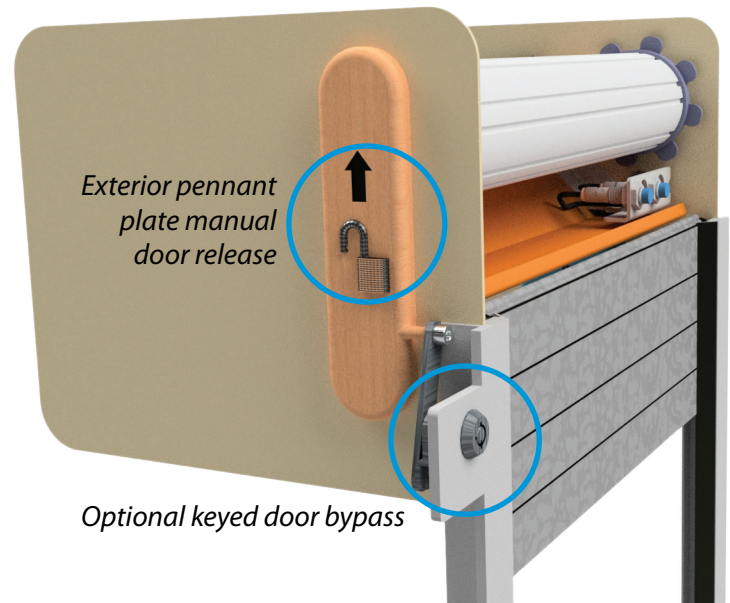

*Wireless outdoor keypad*



*Visit [dynatect.com](http://dynatect.com) for  
an overview video*

## HOW TO SPECIFY

### SO, HOW DO I SPECIFY GORTITE® POWERED DOORS? IT'S EASY!

- Roll-up doors shall be Gortite brand manufactured by Dynatect Manufacturing, Inc.
- Roll-up doors to be constructed of double-sided aluminum extrusions. The extrusions are to be 1-3/8" tall and 3/8" thick with satin anodized finish or painted to match truck body.
- A flexible extrusion shall be installed between each slat to ensure a weather-tight seal
- Aluminum extrusions shall be individually replaceable without disassembling the entire door by removing push out clips on each end
- Side channels for the door to ride in shall be provided with seals to prevent dirt and moisture from entering compartment. A single piece top drip rail shall be provided with a seal to prevent dirt and moisture from entering the compartment when the door is fully closed. Bottom of door will also be provided with a seal.
- All non-metallic parts to be glass-filled nylon
- Lift bar shall be made of stainless steel
- The door shall be capable of operating in temperatures of -40° F to 180° F

- Drive system shall feature three simultaneous modes of motion control
- Mechanical drive system shall employ a positively driven mechanism to prevent doors from drifting closed on inclines or when partially open
- Motor/gearbox to fit into existing idler tube envelope
- Vendor shall have at minimum twenty (20) years of installed and operating roll up door assemblies in field applications

### OUR LIFETIME ROLL-UP DOOR WARRANTY

The roll-up doors have the following warranties to be free from defects in materials and workmanship:

- Lifetime for the spring-loaded roller
- 3 years for all other parts
- 5 years for optional painted finish (free from peeling or blistering)
- 1 year for optional electronic equipment
- Warranties are from date of shipment and apply to the original owner
- Damage due to accidents or external causes are not warranted

### NEED A DOOR SOLUTION WITH CUSTOM FEATURES?

We offer full engineering and design support to integrate into your vehicle with custom features, options and accessories.

## DYNATECT IS AN ESTABLISHED HIGH-VOLUME TIER 1 AUTOMOTIVE SUPPLIER

### DYNATECT AUTOMOTIVE EXPERIENCE/FEATURES INCLUDE:

- Automotive water management compliance
- Automotive brake/squeak/rattle (BSR) compliance
- Optimized ergonomics to minimize repetitive motions and operator strain
- Customizable locks and power-lock options (including signal duration and power draw)
- Customizable latching options
- Motorized door options with key-fob control integrated into BCM
- OEM curved door frames and doors that follow the interior vehicle contour
- OEM frame mountings that facilitate retrofit to swing-out door mounting points
- OEM composite beauty covers

CONNECT

#### GLOBAL HEADQUARTERS

2300 South Calhoun Road  
New Berlin, WI 53151  
USA

phone: +1 262 786-1500  
sales@dynatect.com

DYNATECT.COM